



NATIONAL HIGHWAY AUTHORITY

Ministry of Communications
Government of Pakistan



BIDDING DOCUMENT

FOR

**“OPERATION & MANAGEMENT OF GOJRA REST AREA AT
KM-168+000 NORTH & SOUTH BOUND ON MULTAN –
FAISALABAD – PINDI BHATTIAN MOTORWAY (M-4) ON
ADVANCE NET GUARANTEED RENTAL BASIS”**

Issued to _____

NATIONAL HIGHWAY AUTHORITY
(ROW-Rev Section - Finance Wing)
27-Mauve Area, G-9/1, Islamabad

To: ALL INTERESTED BIDDERS

Subject: **AWARD OF CONTRACT FOR OPERATION & MANAGEMENT OF GOJRA REST AREA AT KM-168+000 NORTH & SOUTH BOUND ON MULTAN - FAISALABAD - PINDI BHATTIAN MOTORWAY (M-4) ON ADVANCE NET GUARANTEED RENTAL BASIS**

INSTRUCTIONS TO BIDDERS (ITB)

Introduction

National Highway Authority (NHA) intends to offer interested Bidders having experience of Operation & Management Contracts (O&M) and registration of PEC in Operator Category of minimum O-4 or above, contract for ***Operation & Management of Gojra Rest Area at KM-168+000 (North & South Bound) on Multan - Faisalabad - Pindi Bhattian Motorway (M-4)***, in terms of advanced quarterly Net Guaranteed Rental basis, which the Operator shall pay to the Employer for operating the Rest Area through competitive bidding.

Briefly, the **Operator shall operate and manage the permissible Rest Area building (already established by NHA) at its own cost** and the Operator have to pay advanced quarterly Net Guaranteed Rent to NHA.

You are hereby invited to submit your bid for the subject Contract. Your bid could form the basis for a contract between you and the Employer i.e. National Highway Authority (NHA).

The detailed brief in respect of Conditions of Contract (CoC), Scope of Contract, Obligations and Covenants, Sample forms, etc. are given in this bidding document.

1. General Conditions of Contract (GCCs): -

1.1 Bidding is open to all interested Bidder(s) with the following must meet criteria:

- a. PEC registered individual/ firm/company falling in operator category minimum O-4 or above shall be eligible having experience of Operation & Management Contracts.
- b. The interested Bidder(s) must not be blacklisted, defaulter or debarred from any of the government department(s) of Pakistan and NHA in any case/shape. In this regard, the prospective Bidder(s) shall submit undertaking on stamp paper to NHA that the firm is neither blacklisted/debarred nor defaulter.

- 1.2 The Operators shall operate and manage the permissible Rest Area at its own cost. Details of buildings along with their dimension and purpose are given in **Annex-A**". On completion of contract period or its early termination, the Operator shall hand over the entire facility to NHA in a properly maintained and operational condition without any claim to cost.
- 1.3 Annual Increment: The net guaranteed rentals shall be increased @ 10% each year accumulatively. The net guaranteed Rentals shall be increased @ 10% each year on the basis of preceding/last year's net guaranteed rentals.
- 1.4 The Operator shall operate and manage the existing buildings and shall not have any rights to establish/construct any new building at or near the premises of site, until/unless so desired by the Employer. In case of necessity/urgency/any change in policy or special directions/ instructions by Government of Pakistan, the same may be allowed by Employer i.e. NHA to anyone it deems fit and operator shall have no rights to object to it.
- 1.5 The Operator shall also provide maintenance, utilities and cost for utilities for all the Rest Area. The procurement is for renting out NHA's assets; therefore, Inventory of Assets will be prepared by General Manager (Region) along with Project Director and shall be signed jointly at the time of Handing over/Taking over. The said inventory shall become the part of this bidding document. The Operator shall be bound to hand over assets as per Inventory at expiry of Contract to the satisfaction of employer.
- 1.6 For mobilization, the Grace Period of one (01) month from the date of issuance of commencement letter shall be allowed to the Operator on completion of which payment to NHA by the Operator shall become due.
- 1.7 The contract period shall be valid for three (03) years, further extendable for a period of two (02) years, subject to satisfactory performance, mutual consent of both parties and subject to approval by NHA.
- 1.8 The interested Bidder(s) shall bear all costs associated with the preparation and submission of its bid and the Employer shall not be responsible or liable for any such costs in any event whatsoever, regardless of the conduct or outcome of the bidding process. Bidder(s) must fully inform themselves of local conditions and all factors related to subject contract whatsoever and take them into account in preparing their bid.
- 1.9 The interested Bidder(s) are advised to visit and examine the Site (as defined in Section I.02 of Article I) and its surroundings and obtain for themselves on their own responsibility all information that may be necessary for preparing the bid and entering into a contract. The Bidder(s) shall be deemed to have checked the traffic volume and prepared its bid accordingly; no claim(s) whatsoever in this regard

shall be entertained thereafter. All costs in this respect shall be at the Bidder's expense.

- 1.10 Sub-letting of any facility(ies) by the Operator shall not be allowed.
- 1.11 The Operator shall be responsible for resolving all the issues which arise between the Operator and any local authority during the currency of the Contract at its own risk & cost and shall indemnify NHA from all legal recourses.
- 1.12 All bids must be properly bound in hard form (to deny removal/addition of any documents), duly signed/stamped with continues page numbering on all pages by the Bidder(s) for submission to NHA. Ring binding, spiral binding and box file form (with loose papers) will not be accepted and such bids shall be considered non responsive.
- 1.13 The Bidder(s) are required to examine carefully the contents of all the documents submitted in their bid. Failure to comply with the requirements of bid submission will be at the Bidders' own risk. Pursuant to Clause 16(b), bids which are not substantially responsive to the requirements of the Bidding Documents will be rejected.
- 1.14 If there arises any discrepancy between bid amount quoted in words & figures, the amount quoted in words will prevail.

2. Single Stage One Envelope System of Bidding/Tendering procedure.

- 2.1 The Employer has adopted Single Stage One Envelope based mode of procurement for this bidding, which is in accordance with the PPRA Rule 36 (a).
- 2.2 In the single stage one envelope bidding procedure Bidder(s) are required to submit their financial bids to NHA along with the must meet criteria as per clause 10, in sealed envelope on the date of bid submission.
- 2.3 The Bidder shall submit one original and a copy (soft & hard) of bid to NHA. Bidders must ensure that their original and copy of bid are contained in separately sealed envelopes clearly marked as indicated above. NHA requires Bidders to submit the separately sealed envelopes in one bound package. In the event of any discrepancy between the original and copies, the original shall govern.
- 2.4 For fulfilling the must meet criteria, NHA will first check the documents regarding must meet criteria. The sealed Financial bids of only responsive and qualified Bidder(s) shall be opened and announced in presence of all the Bidders and tender opening and evaluation (TO&EC) Committee.

- 2.5 The original and copy of the Bid shall be typed or written in indelible ink and shall be signed by a person or persons duly authorized to bind the Bidder to the offer. Proof of authorization shall be furnished in the form of a written Power-of-Attorney, which shall accompany the Bid. All pages of the bid, except for un-amended printed material, shall be initialed by the person or persons signing the Bid.
- 2.6 The complete Bid shall be without alterations, interlineations or erasures, except as necessary to correct errors made by the Bidder, in which case such corrections shall be initialed by the person or persons signing the Bid by deleting old statement and writing new.

3. Clarifications & Correspondence

- 3.1 Prospective Bidder(s) requiring any clarification(s) in respect of the Bidding Documents may notify the Employer in writing or by fax at the following address:

Office of General Manager (ROW-Rev)
27-Mauve Area, G-9/1, Islamabad.
Phone: +92-51-9032729, Fax # 92-51-9032948

- 3.2 Employer will examine the request for clarification of the Bidding Documents, if received not later than ten (10) days prior to the deadline for the submission of bids or during the Pre-Bid meeting, and shall issue a clarification minimum three (03) days before the date of submission of Bids (without identifying the source of enquiry) to all prospective bidders who have purchased or downloaded the Bidding Documents.
- 3.3 At any time prior to the submission/opening of bids, the Employer may, for any reason, whether at its own initiative or in response to a clarification requested by a prospective bidder, modify the Bidding Documents by issuing an addendum.
- 3.4 Any addendum thus issued shall become an integral part of the Bidding Documents.
- 3.5 To afford prospective bidders reasonable time in which to take an addendum into account in preparing their bids, the Employer may at its discretion extend the deadline for submission of bids.
- 3.6 Moreover, the Employer may also seek clarification through writing for any document/item(s) in the bid.
- 3.7 Name and address of the Employer is: -
Chairman National Highway Authority
Mauve Area, G-9/1, Islamabad.
- 3.8 The authorized representative of the Employer is;
General Manager (ROW-Rev) NHA-HQ, Islamabad.

4. One Bid per Bidder

- 4.1 For the said contract, any bidder can only submit one bid. Joint Ventures (JV) is not allowed for participating in the said bidding.

5. Bidders to Inform themselves

The bidders are advised to obtain for themselves at their own cost and responsibility all information that may be necessary for preparing the bid and entering into a contract for operation and management of Rest Areas. This shall include but not be limited to the following:

- (a) Inquiries on Pakistani Income Tax/Sales Tax/Surcharge or any other Levy/Fee/Tax imposed by the Government of Pakistan, Provincial and Local/District Governments. NHA shall not be liable to pay any such Levies/Fee/Tax. Payment of all such applicable taxes is the sole responsibility of the Operator.

6. Local Conditions

Bidder(s) must verify and supplement by its own investigations all necessary information about site, traffic volumes local conditions etc. for the purposes of filling and submitting its bid and entering into the Contract. Any claim(s) in connection to or arising out of these conditions will not be entertained during or after the completion of Contract period.

7. Pre-Bid Meeting

- 7.1 Prospective Bidders are invited, and strongly encouraged, to attend a pre-bid meeting, organized and to be conducted by NHA.
- 7.2 Prior to the Pre-Bid Meeting, Bidders are invited to submit written queries concerning the Contract requirements, the Bidding Documents or other related matters pertinent to the Contract.
- 7.3 All such queries should be submitted to the General Manager (Rev-ROW), NHA, within at least ten (10) working days prior to submission of bid.
- 7.4 The NHA will conduct the pre-bid meeting, record all questions, both written and verbal, posed by Bidders, record all answers provided thereto, and provide a written Pre-Bid meeting Memorandum or, if required, amendment through Addendum in bidding document to each Bidder.
- 7.5 The NHA will not, during the Pre-Bid meeting, modify in any material respect any provision or term of this Bidding Documents unless such modification is made as a written Addendum thereto prepared by the NHA and disseminated to all the Bidders.
- 7.6 Schedule for **Pre-Bid Meeting:** -

Date & Time: Tuesday 25th Feb, 2020 at 1130 hrs.

Venue: NHA Auditorium,
27-Mauve Area, G-9/1, Islamabad

8. Bid Validity

- 8.1 Bids shall remain valid for the period of One Hundred and Twenty (120) days after the date of bid submission.
- 8.2 In exceptional circumstances prior to expiry of original bid validity period, the Employer may request the bidders to extend the bid validity for a specified additional period which shall in no case be more than the original bid validity period. The request and the responses thereto shall be made in writing. A bidder may refuse the request without forfeiture of its Bid Security. A bidder agreeing to the request will be required to extend the validity of its Bid Security for the period of the extension, in accordance with PPRA Rule 26.

9. Bid Security

- 9.1 Each bidder shall furnish, as part of its bid, a Bid Security in the amount of Pak. Rupees 1,000,000/- (Rupees one million only).
- 9.2 The Bid Security shall be, at the option of the bidder, in the form of Bank Draft or a Pay Order issued by a Scheduled Bank in Pakistan acceptable to the Employer in favor of the “*National Highway Authority, Road Maintenance Account, Islamabad*” valid for a period twenty-eight (28) days beyond the bid validity date.
- 9.3 The Bid Security is required to protect the Employer against the risk of bidder’s conduct which would warrant the security’s forfeiture, pursuant to Sub-Clause 9.8, hereof.
- 9.4 Any bid not accompanied by an acceptable Bid Security, shall be rejected by the Employer forthwith as being non-responsive, pursuant to Clause 9.8.
- 9.5 Any amount of bid security which is lying with the Employer for any previous bidding process shall not be considered for this bidding.
- 9.6 The bid security of all participating bidders will be returned as promptly as possible except for the top three (03) highest bidders, which will be returned upon award of Contract to the successful bidder under clause 23, or on the expiry of validity of Bid Security under clause 8, whichever is earlier subject to rights of parties.
- 9.7 The Bid Security of the Successful Bidder will be returned when the bidder has furnished the required Performance Security and signed the Contract, pursuant to Clause 9.6.
- 9.8 The Bid Security may be forfeited:
- (a) if a bidder withdraws its bid during the original period of bid validity; or

- (b) if a bidder does not accept the arithmetic correction of its Bid Price, or
- (c) in the case of an Operator, if it fails to:
 - (i) furnish the required Performance Security in accordance with Clause 23.1 (a); or
 - (ii) sign the Contract, in accordance with Clause 22.

10. Documents Comprising of Bid

10.1 the bid to be submitted by the interested bidder shall comprise the following documents:

a. **Envelope-A** (Documents Consisting Must Meet Criteria)

- ✓ Certificate confirming the receipt as per clause 27,
- ✓ Bid Security,
- ✓ Valid PEC license of Operators minimum category O-4, or above
- ✓ Experience of Operation & Management Contracts, verifiable.
- ✓ Undertaking on stamp paper as per clause 1.1 (b) of GCC.

b. **Envelope-B** (Documents Consisting Financial Bid)

- ✓ Financial bid

10.2 Both of the above envelopes should be sealed separately and marked clearly as “**Documents Consisting Must Meet Criteria (Original + Copy)**” the first envelope and the “**Financial Bid (Original + Copy)**” the second envelope as under:

- | | | | |
|---------------|---|--------------------------------|-----------------|
| a. Envelope-A | - | Original | (Sealed) |
| b. Envelope-A | - | Copy | (Sealed) |
| c. Envelope-B | - | Original | (Sealed) |
| d. Envelope-B | - | Copy | (Sealed) |
| e. Bid | - | Envelope-A + Envelope-B | (Sealed) |

11. Format and Signing of Bid

11.1 All documents comprising Bid including Bid Form and Integrity Pact shall be complete in all respects and properly signed/stamped by the bidder.

11.2 No alteration is to be made in the Form of Bid except in filling up the blanks as directed. If any alteration will be made or if these instructions not fully complied with, the bid may be rejected being non-responsive.

11.3 Each bidder shall prepare one (1) Original and one (01) Copy of the documents comprising the bid as described in Clause 10 and clearly mark them “ORIGINAL” and “COPY” as appropriate. In the event of discrepancy between them, the original shall prevail.

- 11.4 The original and a copy of the bid shall be typed or written in indelible ink and shall be signed by a person or persons duly authorized to sign them. This shall be indicated by submitting a written Power of Attorney authorizing the signatory of the bid to act for and on behalf of the Bidder. All pages of the bid shall be initialed and stamped by the person or persons signing the bid.
- 11.5 The bid shall contain no alterations, omissions or additions, except to comply with instructions issued by the Employer, or as are necessary to correct errors made by the bidder, in which case such corrections shall be initialed by the person or persons signing the bid.
- 11.6 Bidders shall indicate in the space provided in the Form of Bid their full and proper addresses at which notices may be legally served on them and to which all correspondence in connection with their bids and the contract is to be sent.
- 11.7 Bidders should retain a copy of the Bidding Documents as their file copy.

12. Submission of Bids

- 12.1 Each bidder shall submit its bid as under:-
- a. One (01) ORIGINAL and one (01) COPY of the Bid shall be separately sealed and put in separate sealed envelopes and marked as such.
 - b. The envelopes containing the ORIGINAL and COPY will be put in one sealed envelope and addressed/identified as given in Sub-Clause 3.1, hereof.
- 12.2 The Bidder shall paste the Form duly filled in on the inner and outer envelopes as per given sample including;
- a. be addressed to the Employer at the address given in Bidding Document.
 - b. bear the contract name and Date of opening of Bid.
 - c. provide a warning not to open before the time and date for bid opening.
- 12.3 The Bid shall be delivered in person or sent by registered mail at the address of the Employer as given above.
- 12.4 In addition to the identification required in Sub-Clause 12.1 hereof, the inner envelope shall indicate the name and address of the bidder to enable the bid to be returned unopened in case it is declared "late".
- 12.5 If the outer envelope is not sealed and marked as above, the Employer will assume no responsibility for the misplacement or premature opening of the bid.

- 12.6 a) Bids must be submitted to the Employer at the address specified in the Bidding Documents not later than the time and date stipulated in the Bidding Documents.
- b) Bids with charges payable shall not be accepted, nor will arrangements be undertaken to collect the bids from any delivery point.
- c) Upon request, acknowledgment of receipt of bids will be provided to those making delivery in person or by messenger.

12.8 NHA shall receive and keep secure all bids submitted before the date and time specified for Bids Closing.

12.9 The Employer may, at its discretion, extend the deadline for submission of bids by issuing an Addendum; in such a case all rights and obligations of the Employer and the bidders previously subject to the original deadline will thereafter be subject to the deadline as extended.

12.10 Schedule for **Bid Submission & Opening**: -

Date & Time (Submission) : Wed, 4th March, 2020 at 1100 hrs.
Date & Time (Opening) : Wed, 4th March, 2020 at 1130 hrs.

12.11 The address for submission of Bids:

NHA Auditorium

National Highway Authority-HQ, 27-Mauve Area, G-9/1, Islamabad.

13. Language

All bids shall be prepared in the English language.

14. Late Bids

- a. Any bid submitted to the Employer after the deadline for submission of bids shall returned unopened.
- b. Delays in the mail, delays of person in transit, or delivery of a bid to the wrong office shall not be accepted as an excuse for failure to deliver its bid at the proper place and time. It shall be the bidder's responsibility to determine the manner in which timely delivery of its bid will be accomplished either in person, by messenger or by post.

15. Bid Opening

15.1 A Committee consisting of nominated members by the Employer will open the bids in the presence of bidders or their authorized representatives who choose to attend, at the time, date and location advertised in Invitation to Bid i.e.

- i. At 1130 hrs. on Wed, 4th March, 2020 in NHA Auditorium, 27-Mauve Area, G-9/1, Islamabad.

- 15.2 The bidders or their authorized representatives who are present shall sign in a register to evidence their participation.
- 15.3 The bidders' names, bid amounts and the presence or absence of Bid Securities, etc. will be announced by the Employer during the bid opening.

16. Determination of Responsiveness of Bids

- 16.1 Detailed evaluation of bids comprises of the following;
- (a) the Employer will examine the Bids to determine whether;
 - i. the Bid is complete and does not deviate from the requirements of the Contract,
 - ii. any computational errors have been made,
 - iii. required securities have been furnished,
 - iv. the documents have been properly signed/stamped,
 - v. the Bid is valid for the stipulated period,
 - vi. the quoted Bid price shall firm during currency of contract,
 - vii. the Bidder fulfills the must meet criteria as per GCC clause 1.1 for Bid hereof, and
 - (b) A bid is non responsive, if;
 - i. it is neither signed nor stamped,
 - ii. its validity is less than the specified period,
 - iii. it is not accompanied with Bid Security,
 - iv. it is materially and substantially deviant from the requirements of the Bidding Documents.
- 16.2 If the Bidder does not accept the corrected amount of its Bid, it will be rejected and the corresponding Bid Security shall be forfeited.
- 16.3 A Bid determined as substantially non-responsive shall be rejected and cannot subsequently be made responsive by the Bidder by rectification of the non-conformity.

17. Evaluation of Bids

- 17.1 NHA intends to facilitate and sustain an environment of competitiveness, transparency and fairness in the procurement process by, among other means, fairly and impartially processing.
- 17.2 The NHA will examine the Bids to determine whether they are complete, whether the requisite Bid Securities have been furnished, whether the documents have been properly signed, and whether the Bids are generally in order.
- 17.3 Financial Bids of only the responsive bidder(s) who have fulfilled the criteria mentioned in Clause 1.1 of GCC will be opened, announced and put to comparison process. The financial bid(s) of non-responsive bidder(s) shall be returned un-opened.
- 17.4 From the date and time of Bid Opening until the time the Contract is

awarded, any Bidder wishing to contact the NHA on any matter related to this bidding must do so in writing at the NHA's address noted above in clause 3.1.

18. Confidentiality

- 18.1 After the Bid Opening, information relating to the examination, clarification, evaluation and comparison of Bids and recommendations concerning the award of a Contract shall not be disclosed to Bidders, or other persons not officially concerned with such process, until the award of the Contract is officially announced.
- 18.2 Any effort by a Bidder to influence the NHA in the process of examination, clarification, comparison and evaluation of Bids, or decisions concerning award of a Contract, may result in the rejection of that Bidder's Bid and forfeiture of his Bid security.

19. Employer's Right to Accept any Bid and to Reject any or all Bids

As per PPRA Rule 33:

- i. The procuring agency may reject all bids at any time prior to the acceptance of a bid.
- ii. The procuring agency shall upon request communicate to any supplier or contractor who submitted a bid, the grounds for its rejection of all bids, but is not required to justify those grounds.
- iii. Notice of the rejection of all bids shall be given promptly to all bidders.
- iv. The procuring agency shall incur no liability.

20. Award Criteria

The Employer will award the contract to the bidder whose bid has been determined to be substantially responsive to the Bidding Documents and who has offered the highest paying evaluated bid price (net guaranteed rentals).

21. Security Deposits

- 21.1 The Operator shall furnish to the Employer the Performance Security, Rental Security (equal to advance quarterly rental) and Payment of applicable Taxes in the forms and the amounts stipulated below, within a period of fifteen (15) days after the receipt of Letter of Acceptance.

a. Performance Security

The Performance Security shall be equal to 25% of the bid value of yearly net guaranteed rental. The Performance Security should be in form of Pay order drawn in favor of "Road Maintenance Account, National Highway Authority, Islamabad"

b. **Rental Security**

The Rental Security shall be equivalent to three (03) months net guaranteed rental, offered by the Operator. The Rental Security should be in form of Pay order in favor of the “*National Highway Authority, Road Maintenance Account, Islamabad*”.

c. **Payment of Taxes**

The Operator shall deposit applicable taxes, over and above the net guaranteed rentals, in advance in the form of Pay order in favor of the “*National Highway Authority, Road Maintenance Account, Islamabad*”.

21.2 Failure of the Operator to comply with the requirements shall constitute sufficient grounds for the annulment of the award and forfeiture of its Bid Security.

22. Notification of Award

22.1 Prior to expiration of the bid validity prescribed by the Employer, the Employer will notify the Operator in writing through a letter i.e. “Letter of Acceptance” that its bid has been accepted. This letter shall comprise the amount of Net Guaranteed Rental payable to the Employer.

22.2 The Letter of Acceptance and its acceptance by the bidder will constitute the formation of the contract, binding the Employer and the Operator till signing of the formal Contract for Guaranteed Rental.

22.3 Upon furnishing the Performance Security and other requisites by the Operator, the Employer will promptly notify the bidders that their bid has been unsuccessful and return their Bid Security.

23. Signing of Contract

23.1 Within seven (07) days from the date of furnishing of acceptable Performance Security under the Conditions of contract, the Employer will send to the Operator the Form of Contract for Guaranteed Rental attached to the Bidding Documents.

23.2 The formal Contract between the Employer and the Operator shall be executed within seven (07) days of the receipt of such Form of Contract by the Operator.

24. Due Diligence

24.1 NHA reserves the right to carry out due diligence in its sole discretion during procurement, award and execution of the Contract.

24.2 Bidders must adhere to the Contract location, as well as the site boundary limitations.

25. Integrity Pact

Prior to signing of the Contract, the Operator shall sign and stamp the Integrity Pact as per attached sample. Failure to provide signed/stamped Integrity Pact shall make the Operator non-compliant. Failure of the Operator to sign the Integrity Pact within the specified time, shall constitute sufficient grounds for the annulment of the award and forfeiture of its Bid Security.

26. Confirmation of Receipt

Please confirm to the Employer that you have received all the correspondence as prescribed in this Bidding Documents and certificate in this regard must be attached alongwith the bid. The authorised representative of Employer for correspondence/communication is: -

General Manager (ROW-Rev)

National Highway Authority-HQ,
Islamabad.

27. The Bidding Documents consist of followings: -Instructions to bidders (ITB).

- I. Terms & Conditions: - Articles I to XII.
- II. Addendum to the Bidding Documents, *if any*.
- III. Sample Forms.
- IV. Annexures.
- V. Financial Bid Form.

II. TERMS & CONDITIONS

ARTICLE I
TERM OF THE CONTRACT AND CONTRACT SITE

Section I. 01 Term

- a) The Contract shall expire after three (03) years if not further extended for a period of two (02) years which is, subject to satisfactory performance, mutual consent of both parties and approval by NHA. The contract period shall start from the issuance of Letter of Commencement.

Section I. 02 Contract Site

- (a) Operator shall render the services solely within or with respect to the Contract Site, as defined under sub-paragraph (b) and in accordance with the Clause 1.4 & 1.5 of GCC. For the purposes of this Contract, the Operator shall have no rights or obligations beyond the geographical limits of the Permissible Site.
- (b) The Rest Area offered to the Operator by NHA pursuant to this Contract shall be at Gojra Rest Area on KM-168+000 both North & South Bound of Multan – Faisalabad – Pindi Bhattian Motorway M-4 for Operation & Management of the already established buildings consisting of tuck shops, Prayer Halls (Male/Female Separate) & Washrooms. The Operator shall operate and manage the permissible Rest Area at its own cost. On completion of three (03) years' operation, the Operator shall handover all of the amenities/installations to NHA. Exact parameters of the area rented out to the Operator pursuant to this Contract ("Contract Site") is as per Annex-A, pursuant to Clause 1.2 to 1.5 of GCC.

Section I. 03 Definitions and Rules of Interpretation:

All capitalized terms used herein shall have the meanings assigned to them in this Contract.

- a. **"Contract"** means the Contract for Guaranteed Rental, Articles, Conditions of Contract and Appendices.
- b. **"Authority"** means National Highway Authority, Government of Pakistan, Islamabad.
- c. **"Operator"** means the Operations & Management Operator running the Contract in accordance with the terms and conditions of the Contract and the Scope of Contract.
- d. **"Contract Rental"** means the advance quarterly net guaranteed rentals payable to the Employer by the Operator as stated in the Letter of Acceptance (LoA).
- e. **"Day"** means the Calendar Day.

- f. **“Employer”** means the Chairman, National Highway Authority, Government of Pakistan, Islamabad.
- g. **“Employer’s Representative”** means General Manager (ROW-Rev) NHA-HQ, Islamabad or any other person appointed in writing by the Employer from time to time.
- h. **“ITB”** means Instructions to Bidder.
- i. **“Modification of Contract”** is defined as a Contract in writing negotiated and signed between the Employer and the Operator for any change in the original agreement and any obligations associated therewith.
- j. **“Party”** means the Employer or the Operator as the case may be, and Parties means both of them.
- k. **“Qualified Bidder”** means the prospective bidder who fulfills must meet criteria as per Clause 1.1 of GCC.
- l. **“Rental Security”** means the amount equal to the one advance quarter net guaranteed Rentals, which shall be deposited by the Operator to the Employer against security deposit.
- m. **“ROW”** means Right of Way.
- n. **“Scope of the Contract”** means provision of Operations and Management of facilities in accordance with the terms & conditions set in by this bidding document.
- o. **“Services”** means services required to be rendered by the Operator in accordance with various articles of the Contract.
- p. **“Site Location”** means the site which includes buildings as per **Annexure-A** offered for Operation and Management of Gojra Rest Area.

Section I. 05 Notices:

All notices under this contract will be given in writing and will be deemed to have been given if delivered by Registered Post or Courier Services at the specific designation/ addresses of the parties as set forth in this contract with acknowledgement due.

Note: The address for seeking clarification regarding any query/queries is as under: -

General Manager (ROW-Rev)
National Highway Authority-HQ,
27- Mauve Area, G-9/1, Islamabad.
Phone: +92-51-9032729, Fax: +92-51-9032948

ARTICLE II
SCOPE OF CONTRACT AND OBLIGATIONS OF THE PARTIES

Section II. 01 Scope of Contract

- a. NHA hereby grants to the Operator subject to the terms and conditions of this Contract to operate, manage, maintain and provide other ancillary services, as enumerated under Section II. 02 (“Services”), with respect to the Contract operation & Management of Rest Area.
- b. Scope of Contract includes but not limited to the following:
 - i. Maintaining and up keeping of prayer halls/Masjid.
 - ii. Installation of Water Dispensers at rest areas for public.
 - iii. Allocation of place (sitting arrangement) and dedicated parking for special/disabled persons.
 - iv. Installation of Parking Sheds.
 - v. Plantation and beautification.

Section II. 02 Obligations and Covenants of the Operator:

The Services and the obligations of the Operator for contract shall include:

- a. Execution of the Work Plan, including interior designing of the buildings at its own cost and expense; provided that the Operator shall not make any additions, alterations and/or modifications of approved plan, either temporary or permanent, in or around the Contract Site without the written consent of NHA, pursuant to clause 1.4 of GCC.
- b. Ensuring routine maintenance, service and repair of the buildings and the amenities and fixtures at the Contract Site.
- c. Supply of hygienic, nutritious, fresh Halal food and beverages (“Edibles”), at the tuck shop, at reasonable and competitive prevailing market prices; provided that the quality, menu and prices of the Edibles shall be subject to the review as per Govt. Policy and shall accord with established international health and hygiene standards.
- d. Using good quality cutlery, utensils and furniture at the site.
- e. Keeping all parts of the Contract Site, in particular the kitchen of the Tuck Shop, in a sanitary and hygienic state as per existing laws of the land.
- f. Providing appropriate waste/trash cans for the disposal of refuse/waste/trash (“Trash”) in and around the Contract Site

and arranging for removal of Trash from the Contract Site every day.

- g. Establishing and maintaining a computerized sale system at the rest area whereby a record of all the sales (“Record”) at the Tuck Shop shall be maintained, as per existing laws of the land.
- h. Dedicating special place with seating arrangements for elderly citizens and disabled persons.
- i. Dedicated parking on both sides of Rest Area for senior citizens & disabled persons.
- j. Special row in mosque for senior citizen and elderly persons.
- k. Ramps along all amenities for senior citizens and elderly persons.
- l. Special staff for assistance of senior citizens and disabled persons at Rest/Layby Area.
- m. Dedicated/specialized washrooms for senior citizens and disabled persons.
- n. Dedicated place near main parking area, for parking of wheelchairs with staff.
- o. Paying all utility bills, including, bills for electricity, gas, telephone, water and conservancy with respect to inter alia the operation, management and maintenance of the Rest Area and other amenities including Mosque, Ablution Area, Generator Room, Street Lights, etc. at the Contract Site according to their usage in the rest area. Failure will invite encashment of Performance Security & Rental Security.
- p. Operator shall provide new carpets, curtains in the mosque and maintain/replace when needed, during the contract period. Moreover, he will be bound to arrange a suitable Imam Masjid, Moazin, Khudams, Mali and Sweepers (separate for Rest Area and washrooms/toilets) on round the clock basis.
- q. Arranging, at its own expense, alternative/standby arrangements/ generators as necessary in the case of non-availability of electricity or load shedding for 24 hours, 07 days a week and 12 months in a year. Moreover, in case of use of generator provided by NHA all costs associated with operation &

maintenance shall be borne by the O&M Operator at its own cost. No reimbursement shall be made by NHA on this account and any other utilities installed at the Rest Area.

- r. Maintaining a complaint register at the Contract Site at a clearly accessible and visible place including display of telephone/mobile number and e-mail address of the Operator as well as NHA.
- s. Providing suitable and well-organized 24 hours security arrangements like installation of CCTV Cameras on the entire Contract site and its surrounding area and Security Guards for the safety of commuters.
- t. Using the Contract Site solely for defined/given purposes of providing the Services and operation, managing and maintaining the rest area and facilities.
- u. Supplying labor, materials, equipment and other resources necessary for the performance of the Services.
- v. Cooperating with NHA and any authorized person(s) or entity acting on NHA's behalf, with regard to the transfer of the Contract Site to NHA or any person(s) or entity nominated by NHA upon expiry or termination of this Contract.
- w. Maintaining effective Fire Fighting arrangements.
- x. Provide First Aid facility.
- y. Provide drug-free and hygienic services by establishing a drug-free atmosphere in compliance with Govt. policies.
- z. Providing potable drinking water for the use of general public by installation of electric water coolers one each at Mosque and outdoor sitting places for commuters.
- aa. Complying with all terms and conditions of this Contract and all instructions and directions of NHA, as provided from time to time.

Section II. 03 In carrying out its obligations, the Operator represents and covenants that:

- a. There are no legal, criminal & financial default proceedings pending or threatened for the liquidation of the Operator or that

could materially or adversely affect the performance by the Operator of its obligations under this Contract.

- b. The Operator shall at all times maintain its corporate existence in compliance with the Laws of Pakistan.
- c. The Operator shall procure and maintain all consent necessary to perform its obligations under this Contract, give all required notices and allow all required inspections under all consents obtained or applied for by it, in connection with this Contract.
- d. The Operator may assign, delegate or subcontract its rights and obligations pursuant to this Contract subject to the prior written approval of NHA as per clause 1.10 of GCC.
- e. This Contract has been duly authorized, executed and delivered by it and constitutes the irrevocable, legal, valid and binding obligation of it, and
- f. In the event of termination of this Contract by NHA for convenience the Operator shall have no rights to claim damages and shall not seek continuation of performance of services neither shall approach any court in an attempt to restrain NHA from assuming control of the subject/Contract Site.
- g. In no event shall termination for convenience be deemed a default by NHA under this contract.
- h. NHA shall have the right at any time and from time to time during the term, and for any reason whatsoever at NHA's sole discretion, to terminate this contract with respect to all or any portion of the services (such total or partial termination being referred to herein as a "Termination for Convenience"). NHA may exercise its right of Termination for Convenience by furnishing to Operator written notice of its election to do so, which notice shall specify the services that NHA has elected to remove from the scope and operation of this Contract. The Termination for Convenience as to such services shall be effective sixty (60) days following the date of such notice. Thereafter all references herein to "Services" shall be deemed to refer only to those operation and management tasks that continue to be required to be performed by Operator hereunder. In the event of termination of this Contract by NHA for convenience the Operator shall not seek continuation of performance of services neither shall approach any court in an attempt to restrain NHA from assuming control of the contract site.

Section II.04 Committee for Assessment of the Damages in case of termination at NHA's Convenience:

In case of early termination due to convenience of NHA, the following assessment committee will assess the claims for damages submitted by the Operator and recommendations in this regard shall be forwarded for perusal of the Chairman NHA through General Manager (ROW-Rev) for indemnifying the loss of Operator: -

General Manager (Region)	Chairman
Director (Audit)	Member
Director (Legal)	Member
Deputy Director (FR/HB)	Member
Deputy Director (Maint)	Member
Assistant Director (ROW-Rev)	Member

Section II.05 The Employer's Representations, Warranties and Covenants

NHA hereby represents and warrants to the Operator that as of the date of this Contract:

- a. It is duly created pursuant to the National Highway Authority Act, 1991 and has complied fully with all applicable Laws of Pakistan in the grant of this contract;
- b. The Contract Site falls within the jurisdiction of NHA and that NHA is duly authorized under the Laws of Pakistan to enter into the contract with regard to the Contract Site;
- c. This Contract has been duly authorized, executed and delivered by it and constitutes the legal, valid and binding obligations of NHA; and
- d. NHA shall exercise its powers under the National Highway Authority Act, 1991, the rules and regulations framed there under and all other Laws of Pakistan and amendments made thereto in a manner that is consistent with this Contract;
- e. NHA shall use its good offices to support the Operator's performance of its business activities pursuant to the contract, but without assuming any liability or obligation in this regard unless expressly stated in this Contract;
- f. NHA shall make available or cause to be made available to the Operator the Contract Site, operation and management of the Gojra Rest Area as per approved plan free of all encumbrances, lien and charge;
- g. NHA shall ensure that access to the Contract Site is not closed or restricted in any way;

- h. NHA shall use its good offices if requested and facilitate the Operator in obtaining permissions and licenses required from time to time for the purposes of the Contract, however it is not an obligation;
- i. NHA shall grant or assist the grant or processing of applications for any work permits, employment passes, visas and other permits, as necessary for the Operator, its directors, employees, and other individuals employed for performance of its obligations pursuant to this Contract in accordance with the laws of Pakistan; and
- j. NHA will comply with all the terms and conditions of this Contract.

Section II.06 Quality Assurance

For the purpose of Quality Assurance, bidder should have to follow the best international practices of quality assurance and checking procedure. Following yardsticks may be followed:-

- i. There shall also be a mechanism to keep clothing of the staff neat and clean at all the times.
- ii. The provision of food and services should be of National standards and at the notified prices by Government of Pakistan.
- iii. The staff shall be courteous to the road commuters and follow best practices while imparting services.
- iv. Only fresh and hygienic food stuff will be served 24 hours in the Rest Area.
- v. There should be potable water/electric coolers installed duly visible at different locations for the ease and facilitation of public. The water electric coolers should be operational 24/7.

ARTICLE III
TERMS AND CONDITIONS OF PAYMENT & PENALTIES

Section III. 01 Terms and conditions of payment

- a. The general terms and conditions with regard to the payments to be made by the Operator pursuant to the Contract are as under:
- (i) The Contract is based upon fixed Rental payment arrangement between the successful Operator and NHA. NHA shall receive advance quarterly net guaranteed Rental sum amounting to ("amount quoted in the Bid"), notwithstanding the actual revenue collected/generated by the Operator from the Contract Site. The Advance Quarterly Net Guaranteed Rental amount with respect to any year of the Term shall be enhanced at the rate of ten (10) percent of the Advance Quarterly Net Guaranteed Rental of the preceding year accumulatively.
- (ii) The successful Operator shall deposit the advance guaranteed rentals for three (03) months in NHA designated account. Upon completion of three (03) months, if the successful Operator fails to deposit the advance net guaranteed Rental for next three (03) months by 5th of the calendar month then an amount of Rs. 5,000/- per day shall be charged upto 15th of each calendar month. After delay of 15 days from the due date, contract shall become liable to be terminated under default of Operator including encashment of performance guarantee and rental security.
- (iii) All payments due under this Contract shall be in Pakistani Rupees;
- (iv) All taxes including income tax shall be paid by the Operator according to the prevailing income Tax Laws in Pakistan over and above net guaranteed rentals; and
- b. The Operator shall deposit three (03) months guaranteed Rentals in advance to NHA in addition to performance security. The Operator shall be refunded the Performance Security upon expiry of the Term, after clearance of all outstanding liabilities of the Operator pursuant to the Contract, Any structural or cosmetic damage caused to the Contract site due to the willful or negligent acts or omissions of the Operator or the employees, agents, servants or representatives thereof, shall be deducted from the Security, provided that deposit of the Security shall not absolve the Operator of its liabilities and duties pursuant to this Contract nor shall it indemnify the Operator in the event of default in paying the Guaranteed Rental to NHA.

**ARTICLE IV
TRADE NAME AND ADVERTISEMENT**

Section IV .01

- a. The Operator shall only use and display its proprietary trade name in marketing and advertisement its services pursuant to this Contract, provided that NHA shall at all times retain a right to display its name and or messages in the form of advertisement at the Contract Site.
- b. The Operator shall advertise about the Rest Area and other facilities at its own cost and expense, subject to the prior approval of NHA. The Operator shall not display advertisements or signs that are environmentally damaging, dangerous for highway safety, or against the social culture of Pakistan.
- c. During the term, NHA shall retain the right to lease open space within the Contract Site for third party advertisement or any other use as it may deem fit at its sole discretion and operator shall have no rights to object to it.
- d. The Operator shall remove all its signboards, and advertisements immediately upon termination or expiry of this Contract. No additional time beyond the contract period shall be granted/allowed for the same. In case of failure by the operator regarding clearance/removal of all its installations, goods, supplies, the same shall become the asset of NHA and operator shall not be entitled for claiming anything.

ARTICLE V PUBLIC UTILITIES

Section V.01 Limit of NHA Obligation

NHA shall provide on the Operator's request in a timely manner, such information as it holds or is available in respect of public utilities provided at the Contract Site; provided that NHA shall not be liable to reimburse the Operator for any loss, damage or expense incurred by the Operator as a result of inaccurate or late information being provided by NHA.

Section V.02 Facilities

Drinking Water Cooler

The Operator shall arrange at its own all the facilities including drinking water and must ensure provision of electric cooler at mosques, tuck shop for the use of general public.

Surveillance cameras

Operator shall be responsible to install and cover all the Rest Area with surveillance cameras round the clock having sufficient storage capacity of data for security purpose at its own cost.

Section V.03 Application for supply

In relation to the supply of public utilities and services required by the Operator to effectively perform the Services, NHA shall not be responsible for submitting or procuring any applications in respect thereof to the relevant public utility authorities, companies or undertakings charged with the responsibility for the same.

Section V.04 Coordination of Works

The Operator shall not be responsible for the costs and expenses of any works that may be carried out by the relevant public authorities and companies at the Contract Site that are not necessary for performance of the Services.

Section V.05 Access to Contract Site for Public Utilities

The Operator shall permit at any time during the Term the authorized personnel of a public utility provider to have access to the Contract Site for the purpose of:

- a. Routine maintenance of any public utility already located within the Contract Site;
- b. The strengthening, replacing or upgrading of any public utility already located within the Contract Site;

- c. Reinstating any foundations, structures, buildings, pavements, cabling and the like which may be disturbed or affected by reason of such works undertaken by a public utility provider, or
- d. Any other work including the installation of any new additional services of the public utility provider within the Contract Site.

Section V.06 Payment for Utilities

The Operator shall be responsible for the payment of all utility bills and POL/Maintenance of stand by generators for the Contract Site in its area of jurisdiction including but not limited to street lights to be paid by Operator of Rest Area on actual basis in accordance with the provisions of Article II of this Contract.

ARTICLE VI
THE NHA REPRESENTATIVE AND EMPLOYEES OF THE OPERATOR

Section VI.01 Employer Representative

The Employer representative for field supervision will be General Manager (Region). He will supervise Contract site through PD/DD (Maintenance/Revenue) and will be responsible to implement the Contractual Obligations of Operator.

Section VI.02 Staff of the Operator

- a. The Operator shall, at its own cost and expense, hire the services of skilled and unskilled staff ("Employees") for the operation, management and supervision of Rest Area. List of the employees that shall be hired for this purpose shall be maintained with the Supervisor of the concerned field staff as a record for verification.
- b. NHA may in its sole discretion deem an employee unfit to perform services at under this contract. Such employee shall be immediately removed by the Operator besides taking other course of action required as per Legal way and Law upon the request of NHA and shall not be reappointed to perform any work under this contract except with the written consent of NHA. In the event that NHA elects to exercise its power under this provision, the Operator shall have no right to any compensation whatsoever for any loss consequential to the exercise of such power.
- c. The Employees shall be in proper uniform and must be capable of providing services pursuant to the Contract in an honest, courteous and efficient manner.
- d. If at any time after provision of the List, the Operator desires to recruit or dismiss an employee, the Operator shall forthwith notify NHA of such recruitment or dismissal, to update list of employees all the times.
- e. The Operator shall promptly notify NHA if with respect to an employee (s) any disciplinary action has been commenced or taken by the Operator, or (II) any criminal proceedings have been initiated or concluded.
- f. The Operator shall comply with all prevailing laws, rules and regulations of Pakistan with regard to rights and obligations of the Employees.

ARTICLE VII DEFAULT

Section VII.01 Defaulting events along with penalty

- a. The occurrence of any one or more of the following events shall constitute an event of default by the Operator under this Contract:
 - i. Addition or deletion of any business/facility without prior written agreement with the Employer i.e. NHA;
 - ii. Indulgence in fraudulent acts;
 - iii. Failure to promptly reimburse NHA for any loss or damage caused thereto attributable at an act or omission of the Operator;
 - iv. Delay in commencement or discontinuance by the Operator in the performance of obligations under this contract;
 - v. Failure to pay the Advance Net Guaranteed Rental amount to NHA timely as committed in this Contract.
 - vi. Insolvency, bankruptcy or liquidation of the Operator;
 - vii. Failure by the Operator to perform any component of the contract in a manner specified in the contract.

- b. If the Operator commits a default as set out herein above, NHA shall be entitled to exercise the following rights in addition to any or all remedies available to NHA under the law:
 - i. Will encash performance security and Rental security.
 - ii. NHA may terminate this Contract immediately alongwith blacklisting of the Operator on the recommendation of GM (ROW-Rev);
 - iii. NHA may fine the Operator upon each occurrence of a defaulting event. The fine shall range from Rupees ten thousand (Rs. 10,000/-) to Rupees one Lac (Rs. 100,000/-), the exact fine depending on the severity of the defaulting event to be determined by a representative from ROW Section NHA nominated by GM (ROW-Rev); and
 - iv. NHA may confiscate the Security deposits i.e. Performance and Rental Securities deposited by the Operator to the Employer for the said contract.

ARTICLE VIII EXPIRY AND TERMINATION

Section VIII.01 Expiry Date of Contract

Contract shall be valid for a period of three (03) years from the date of issuance of Letter of Commencement. The Contract period would be extendable for a period of two (02) years, subject to satisfactory performance, mutual consent of both parties and subject to approval by NHA.

Section VIII.02 Early Termination of the Contract

- a. NHA shall have the right to terminate this Contract or particular services being rendered pursuant to this Contract, for convenience as determined in its sole discretion, at any time during the Term. NHA may exercise this right by furnishing a written notice to the Operator of its action to do so, that the Contract is being terminated. Such termination shall be effective following the date as mentioned in such notice. Thereafter, all references to the obligations under this Contract shall be deemed to refer only to any particular part of the obligations with respect to which this Agreement has not been terminated.

- b. In case NHA fails to provide peaceful possession of contract site, free of all encumbrances, the Operator may give notice to NHA in writing, specifying the default and requiring NHA to rectify the same within sixty (60) days from the date of such notice. If NHA fails to remedy/rectify the said default within the given time period, the Operator shall have the right to issue final notice for termination of contract on NHA, which shall become effective sixty (60) days from the date of the Termination Notice and in this case NHA will release the Securities deposits of the Operator.

ARTICLE IX FORCE MAJEURE

Section IX.01 General

Force Majeure means an event which is not caused by and is beyond the reasonable control of either Party and whose occurrence could not have been reasonably foreseen at the date of this Contract by exercise of due diligence and which makes performance of this Contract impossible in the sense or mode contemplated by the Parties or so impractical as to be considered so impossible under the new circumstances, and includes, but is not limited to war, invasion, riots, insurrection, civil commotion, acts of terrorism in that particular locality only, unusual flood, major earthquake, volcanic activity, radiation or chemical contamination, ionizing radiation, explosions, serious epidemics, any amendment in legislation by Government, any judgment/order passed by the Honorable Supreme Court regarding termination of the subject Contract or its any portion, or any act of God.

Section IX.02 Notice of Force Majeure

If either Party is unable to perform or fulfill any of its obligations under this Contract, as a result of an event of Force Majeure, it shall give notice within twenty (20) days of the occurrence thereof to the other Party.

Section IX.03 Termination/Suspension due to Force Majeure

Neither party shall by reason of such eventuality, be entitled to terminate this Contract nor shall either party have any claim for damages against the other in respect of such non-performance of this Contract shall be resumed as soon as practicable after such eventuality has come to an end or caused to exist provided that if the performance in whole or party of any obligation under this Contract is delayed by reason of any such eventuality for a period exceeding fifteen (15) days, the Parties shall meet and review in good faith the desirability and conditions of terminating this Contract or suspension of the contract up to maximum 182 days.

Section IX.04 Extension of Time due to Force Majeure

If the operations at site remain suspended for more than 15 days but become operational within 182 days during the currency of contract, the Operator will be granted extension of time for compensating him. The Extension of Time shall be exactly equal to that time period, for which the sites were not remained operational due to event(s) of force majeure.

Section IX.05 Continuation of the Contract

The Parties acknowledge that it is in their mutual interest that to the extent possible, decisions concerning Force Majeure shall be directed towards the continued operation of the Contract for the full duration of the Term as provided in this Contract.

ARTICLE X
TRANSFER UPON EARLY TERMINATION OR EXPIRY

Section X.01 Transfer upon early termination or expiry

- a. Upon early termination or expiry of this Contract in accordance with the terms and conditions set out herein, the Operator shall immediately cease to enjoy rights under the contract and shall remove all the Employees, workmen, employees, servants, agents engaged in operation of contract immediately on the date on which the termination or expiry takes effect and clear the site for NHA or duly nominated representative thereof, in a properly maintained & operational condition.
- b. The NHA shall, inspect the Contract Sites and assets thereon including all civil works, installations, equipments and facilities and shall issue an inventory to Operator specifying the condition of the assets thereon and whether Operator has failed to abide by any of its obligations under the Contract.
- c. Upon early termination or expiry of this Contract, the rights and entitlements of Operator pursuant to this Contract shall revert to, vest in or remain vested in the NHA, as the case may be.
- d. Operator shall ensure that the Contract Site and other assets under the contract upon the date of early termination or expiry become free of all liens and charges.
- e. If this Contract is terminated pursuant to Sections VIII.02 (a) or VIII.02 (b), then an amount equal to the assessed value of the facility by the designated committee shall be reimbursed to the Operator as demobilization charges.
- f. Notwithstanding any dispute between the Parties or any claim against NHA, the Operator shall hand over vacant and peaceful possession of the Contract Site and other assets thereon to NHA in accordance with the terms and conditions as set out in this Contract. Any dispute between the Parties or any claims of the Operator against NHA shall not in any case entitle the Operator to refuse or delay the transfer of these assets to NHA. Failure by the Operator to do so in accordance with the terms and conditions of this Contract shall be treated as encroachment and unauthorized occupation by the Operator and may be dealt with by NHA under Section 12 of the National Highway Authority Act, 1991 as amended in 2001.

ARTICLE XI RESOLUTION OF DISPUTES

If any dispute or difference of any kind whatsoever arises between the Operator and the NHA in connection with or arising out of the Contract or performance of the obligations whether during the progress of the obligations or after its completion or after its termination, abandonment or breach of the Contract, it shall in the first place be referred to:

- I. The Employer Representative General Manager (ROW-Rev), NHA shall be served with a notice containing the cause of action, mentioning facts of the case and relief sought. The General Manager (ROW-Rev) shall decide the dispute within twenty-eight (28) days of the receipt of such notice or any extended period with the mutual consent of parties.
- II. If the Operator is dissatisfied with the decision of the General Manager (ROW-Rev) or if the decision of the General Manager (ROW-Rev) is not forthcoming within the stipulated or extended period, the Operator may within two (02) weeks from the receipt of the decision of the General Manager (ROW-Rev) or expiry of twenty-eight days' time refer the matter to the Member (Finance) along with the cause of action, mentioning facts of the case and relief sought. The Member (Finance) will act as a Sole Adjudicator and shall decide the matter within twenty-eight (28) days from the date of submission or any extended period with the mutual consent of parties.
- III. The Operator, if dissatisfied with the decision of the Adjudicator shall have the right to serve Notice for Intention to commence litigation within twenty-eight (28) days of receipt of the Adjudicator's decision or within twenty-eight (28) days after the expiry of the period stipulated herein above for decision of the Adjudicator in case he fails to give decision. Place of litigation shall be Islamabad.

Provided however, that the parties shall have the right at resolution of disputes amicably within fifty-six (56) days of service of Notice for Intention to commence litigation and shall commence in case of failure of amicable settlement.

ARTICLE XII MISCELLANEOUS

Section XII.01 Variations in Writing

This Contract may be varied or amended only by the mutual consent of the Parties. All such variations and amendments shall be binding only if they are in writing and are signed by duly authorized representatives of the Parties. Any addition or deletion of obligations, rights or business will be effected in form of a V.O. to the Contract.

Section XII.02 Waivers

- a. No waiver by either Party of any default by the other in the performance of any of the provisions of this Contract shall operate or be construed as a waiver of any other or further default whether of a like or different character.
- b. The failure by either Party to insist on any occasion upon the performance of the terms, conditions and provisions of this Contract or time or other indulgence granted by one Party to the other shall not thereby act as a waiver of such breach or acceptance of any variation.

Section XII.03 Insurance Coverage from 'AA' Rated Insurance Companies.

- a. The Operator shall obtain and maintain during the pendency of contract, insurance for all assets of Employer handed over to Operator for performing services under this contract against loss & damage due to any reason.
- b. The Operator shall obtain and maintain during the pendency of contract, insurance for Operator's Equipment and other things brought onto the Site by the Operator, for a sum sufficient to provide for their replacement at the Site.
- c. Operator shall obtain and maintain comprehensive health insurance for its entire staff working on Contract Site.
- d. Operator shall maintain during the currency of contract, insurance for all its employees working on Contract Site against injury or death having a minimum coverage of Rs.500,000/- in case of death and Rs.200,000/- for each case of injury/disability with unlimited number of incidents.
- e. The premium for such insurances shall be paid by the Operator.

Section XII.04 Compliance with Government Rules and Regulations

The Operator shall, during the Term of this Contract, strictly comply with all laws, policies, guidelines, rules and regulations now existing or hereafter promulgated by the Government of Pakistan and/or NHA. All policies, guidelines, rules and regulations and all applicable laws, shall be read into and made integral parts of this Contract.

Section XII.05 Headings; Grammatical Usage; Names

Words in the singular number are deemed to include the plural when the sense requires, and the plural shall similarly include the singular. Where the government agencies are named, the name used is deemed to include any successor agency in the event the name is changed or the relevant functions are transferred.

Section XII.06 Non-Relief from Accrued Liability

The termination of this Contract shall not relieve either Party of any liability that may have already accrued pursuant to the terms of this Contract.

Section XII.07 Applicable Law

- a. This Contract shall be governed by and construed in accordance with the Laws of Pakistan.

Section XII.08 Limit of Rights

The rights given under this Contract to the Operator in respect of the land made available to it do not confer upon the Operator any proprietary right, title or interest over such land.

III. ADDENDUM TO THE BIDDING DOCUMENT, IF ANY

IV. SAMPLE FORMS

FORM OF ENVELOPE LABEL

ORIGINAL BID + 01 COPY

WARNING: DO NOT OPEN BEFORE: _____

Bid Title: _____

Package: _____

Bid Opening Date: _____

To:

General Manager (ROW-Rev)
National Highway Authority-HQ
27-Mauve Area, G-9/1, Islamabad

From:

Name of Bidder: _____

Address: _____

Phone Number: _____

Fax Number: _____

CONTRACT FOR NET GUARANTEED RENTAL BASIS FOR

OPERATION & MANAGEMENT OF GOJRA REST AREA AT KM-168+000 NORTH & SOUTH BOUND ON MULTAN - FAISALABAD - PINDI BHATTIAN MOTORWAY (M-4) ON RENTAL BASIS

PREAMBLE

This Contract for Net Guaranteed Rental hereinafter referred as “Contract” is entered into at Islamabad on this the _____ day of _____ 2019 (“Effective Date”).

BETWEEN

(1) **National highway Authority** (“hereinafter called Employer”). A body corporate established under the National Highway Act 1991 (Act XI of 1991) and having its office at 28-Mauve Area, G-9/1, Islamabad, represented through its Chairman, legal assignees and successor in office (1st Party).

AND

(2) **“Bidder Name”** duly incorporated, registered and existing under the applicable Laws of Pakistan, with its registered office at _____ Pakistan (“Name of Operator”, which expression shall include where the context so permits its successors-in-interest and permitted assignees) OF THE OTHER PART.

The NHA and the Operator hereinafter individually referred to as “Party” and collectively as “Parties”.

WITNESSETH:

WHEREAS the NHA offered “Operation & Management Of Gojra Rest Area At KM-168+000 North & South Bound On Multan – Faisalabad - Pindi Bhattian Motorway (M-4)” against Advance Quarterly Net Guaranteed Rentals amounting to Rs. _____, (to be increased @10% per annum accumulatively in the subsequent years) which the bidder shall pay to the Employer in consideration of the right to utilize NHA’s land, for a period of three (03) years further extendable for a period of two (02) years, subject to satisfactory performance, mutual consent of both parties and subject to approval by NHA. The payment to NHA shall be due towards the Operator after expiry of the grace period which is mentioned in letter of commencement. The contract should be performed by the Operator strictly in accordance with the requirements of Employer as set out in the contract documents.

NOW THIS AGREEMENT WITNESSETH AS FOLLOWS:

1. In this Agreement words and expressions shall have the same meanings as are respectively assigned to them in the Conditions of contract referred to.
2. The following documents shall be deemed to form and be read and construed as part of this Contract, in the following order of priority:
 - I. Contract
 - II. Conditions of Contract: Articles I to XII.
 - III. Addendum to Bidding Document (if any)
 - IV. Financial Proposal Forms
 - V. Annexures
 - VI. Bid Form
 - VII. Sample Forms

VIII. Invitation to bid (ITB)

IN WITNESS whereof the parties hereto have caused this Contract to be executed in the day and year first above written.

Signature of the Operator

(Seal)

Signature of Employer

(Seal)

Signed, Sealed and Delivered in the presence of:

Witness:

(Name, Title and Address)

Witness:

(Name, Title and Address)

(INTEGRITY PACT)

DECLARATION OF FEES, COMMISSION AND BROKERAGE ETC.
PAYABLE BY THE OPERATOR, SERVICES & WORKS IN
CONTRACTS WORTH RS.10.00 MILLION OR MORE

Contract No. _____ Dated _____
Contract Value: _____
Contract Title: _____

..... [name of Operator] hereby declares that it has not obtained or induced the procurement of any contract, right, interest, privilege or other obligation or benefit from Government of Pakistan (GoP) or any administrative subdivision or agency thereof or any other entity owned or controlled by GoP through any corrupt business practice.

Without limiting the generality of the foregoing, [name of Operator] represents and warrants that it has fully declared the brokerage, commission, fees etc. paid or payable to anyone and not given or agreed to give and shall not give or agree to give to anyone within or outside Pakistan either directly or indirectly through any natural or juridical person, including its affiliate, agent, associate, broker, consultant, director, promoter, shareholder, sponsor or subsidiary, any commission, gratification, bribe, finder's fee or kickback, whether described as consultation fee or otherwise, with the object of obtaining or inducing the procurement of a contract, right, interest, privilege or other obligation or benefit in whatsoever form from GoP, except that which has been expressly declared pursuant hereto.

[name of Operator] certifies that it has made and will make full disclosure of all agreements and arrangements with all persons in respect of or related to the transaction with GoP and has not taken any action or will not take any action to circumvent the above declaration, representation or warranty.

[name of Operator] accepts full responsibility and strict liability for making any false declaration, not making full disclosure, misrepresenting facts or taking any action likely to defeat the purpose of this declaration, representation and warranty. It agrees that any contract, right, interest, privilege or other obligation or benefit obtained or procured as aforesaid shall, without prejudice to any other rights and remedies available to GoP under any law, contract or other instrument, be voidable at the option of GoP.

Notwithstanding any rights and remedies exercised by GoP in this regard, [name of Operator] agrees to indemnify GoP for any loss or damage incurred by it on account of its corrupt business practices and further pay compensation to GoP in an amount equivalent to ten times the sum of any commission, gratification, bribe, finder's fee or kickback given by [name of Operator] as aforesaid for the purpose of obtaining or inducing the procurement of any contract, right, interest, privilege or other obligation or benefit in whatsoever form from GoP.

Name of Employer:**[Seal]**

Name of Operator: **[Seal]**

Signature:

Signature:

V. ANNEXURES

Annex-A

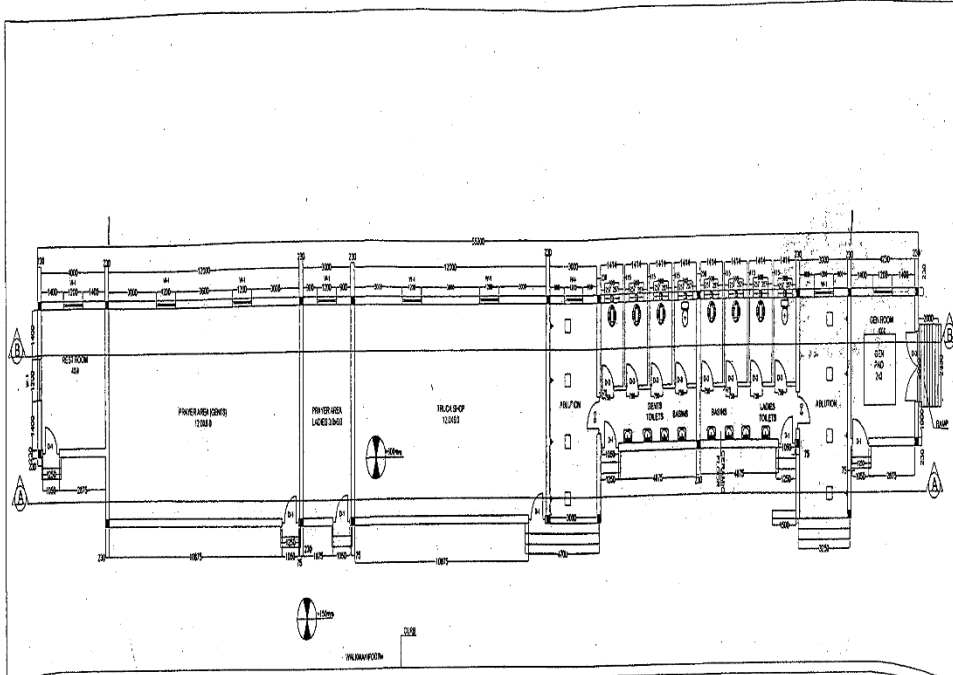

FLOOR PLAN

SCHEDULE OF DOOR & WINDOW				
S.NO	TYPE	SIZE	SILL HEIGHT	DESCRIPTION
1	D1	1050X2150		STEEL FRAME+WOOD PANEL WITH FIBER GLASS
2	D2	900X2150		
3	D3	750X2000		Door Comprising steel shutter Louver
4	D4	2000X2800		
5	W1	1200X1250	900	ALUMINUM+GLASS
6	V1	900X750	1250	ALUMINUM+GLASS

Recommended for Approval.

[Signature]
SE 24

RENARDET S.A. Consulting Engineers
 Approved for Construction
 Date: 1/4/18 Signature: *[Signature]*
 Resident Engineer: M-4 Pkg-11A

Employer: National Highway Authority Ministry of communication Government of Pakistan	Consultant: Renardet S.A. ENGINEERING CONSULTANTS CHATELAINBOULEVARD	Contractor: Xinjiang Beixin Road & Bridge Group Co., Ltd BEIXIN	Project: Motorway (M-4) Package-11A Gojra-Jamail	Title: REST AREA FLOOR PLAN	Submitted: <i>[Signature]</i>
			Ref: BXM4ARSACEJDN8	Date: 09/03/2018	Drawing No.: MA-PI-A-CD-PA-A-01

"OPERATION & MANAGEMENT OF GOJRA REST AREA AT KM-168+000 NORTH & SOUTH BOUND ON MULTAN - FAISALABAD - PINDI BHATTIAN MOTORWAY (M-4) ON ADVANCE NET GUARANTEED RENTAL BASIS"

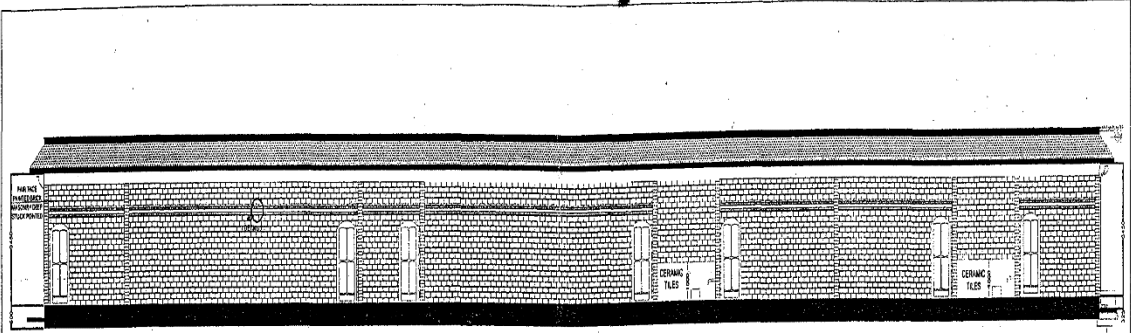

FRONT ELEVATION

RENARDET S.A. Consulting Engineers
 Approved for Construction
 Date: 11/9/18 Signature: *[Signature]*
 Resident Engineer M-4 Pkg-IIA

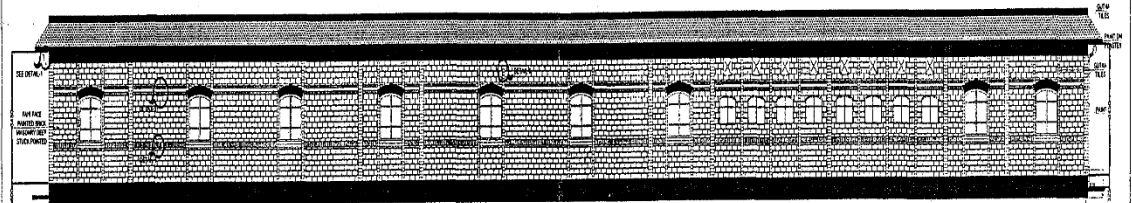

REAR ELEVATION

NOTE:
 01- ALL DIMENSIONS ARE IN MILLIMETER
 02- Safety Grill shall be Provided in the Rear Side of Window.

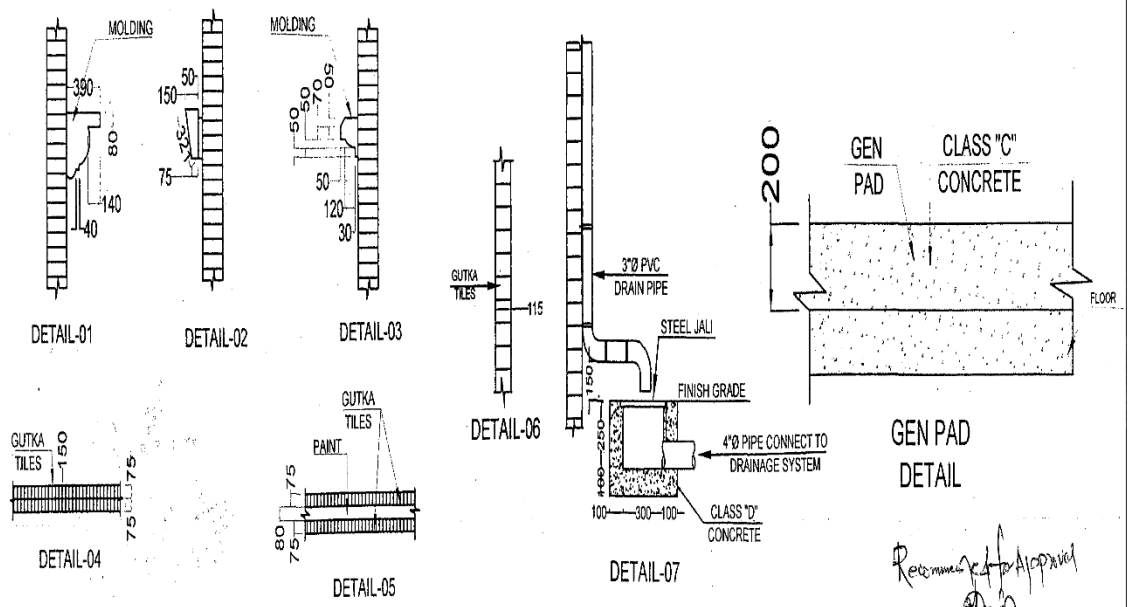

Recommended for Approval
[Signature]

Employer: National Highway Authority Ministry of communication Government of Pakistan	Consultant: Renardet S.A. CONSULTING ENGINEERS	Contractor: Xinjiang Beixin Road & Bridge Group Co., Ltd. 	Project: Motorway (M-4) Package-IIA Gojra-Jamali Ref: BX/M4/R/SACD/2018/ 911	Title: REST AREA ELEVATIONS & DETAILS Date: 19/03/2018	Submitted: 19/03/2018 Approved: <i>[Signature]</i>
---	---	--	---	---	---

"OPERATION & MANAGEMENT OF GOJRA REST AREA AT KM-168+000 NORTH & SOUTH BOUND ON MULTAN - FAISALABAD - PINDI BHATTIAN MOTORWAY (M-4) ON ADVANCE NET GUARANTEED RENTAL BASIS"

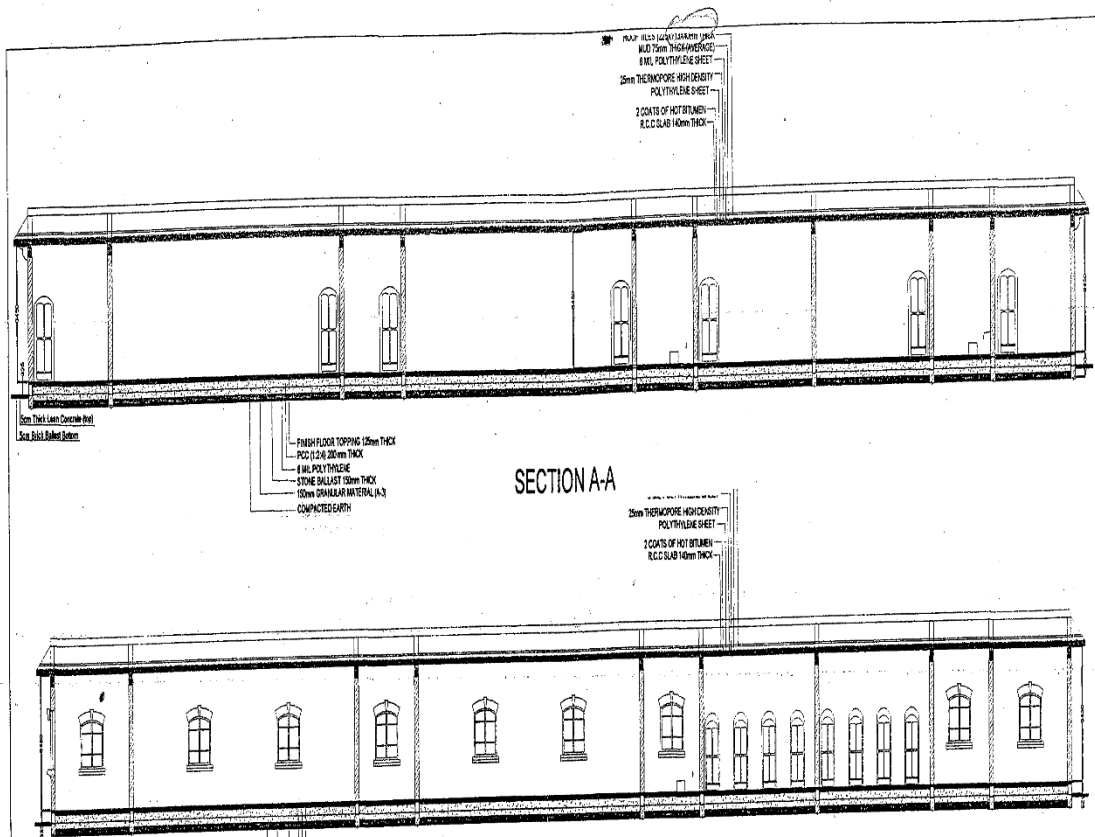

15mm Thick Lean Concrete Bed
Base Ball Joint System

FINISH FLOOR TOPPING 15mm THICK
P.C.C (1:2:4) 20mm THICK
4 MIL POLYETHYLENE
STONE BALLAST 150mm THICK
150mm GRANULAR MATERIAL (M-3)
COMPACTED EARTH

RENADET S.A. Consulting Engineers
Approved for Construction
Date: 1/4/18 Signature: [Signature]
Resident Engineer M-4 Pkg-III

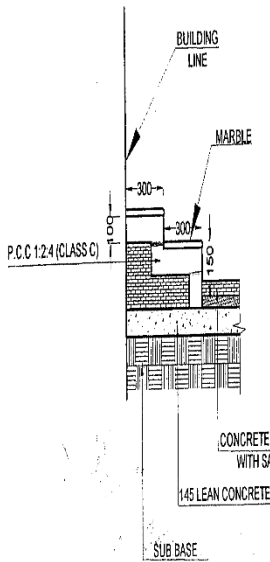

- NOTE:**
- 01- ALL DIMENSIONS ARE IN MILLIMETER.
 - 02- Providing and laying of 12"x12" Pre Polished marble tiles 3/4" thick for flooring, bedding of 1:2 cement sand mortar i/c finishing
 - 03- Providing and Laying of 5mm thick ceramic tiles for dado (Bathroom Walls)
 - 04- Providing and laying of 1/2" thick 6"12" Pre polished Marble tile for skirting with 1:2 cement sand mortar

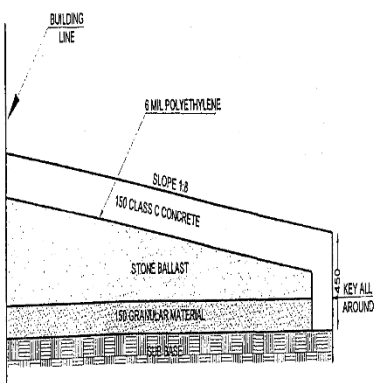

Recommending for Approval
[Signature]

Employer: National Highway Authority Ministry of communication Government of Pakistan	Consultant: Renadet S.A. CONSULTING ENGINEERS	Contractor: XinJiang Detsin Road & Bridge Group Co., Ltd BEIXIN	Project: Motorway (M-4) Package-III A Gojra-Jamami	Title: REST AREA SECTIONS & DETAILS	Submitted: [Signature]
			Ref: BX/M/URS/CE/2018/ 90	Date: 19/3/2018	Drawing No.: M-PIA-CD-PA-A-03

“OPERATION & MANAGEMENT OF GOJRA REST AREA AT KM-168+000 NORTH & SOUTH BOUND ON MULTAN - FAISALABAD - PINDI BHATTIAN MOTORWAY (M-4) ON ADVANCE NET GUARANTEED RENTAL BASIS”

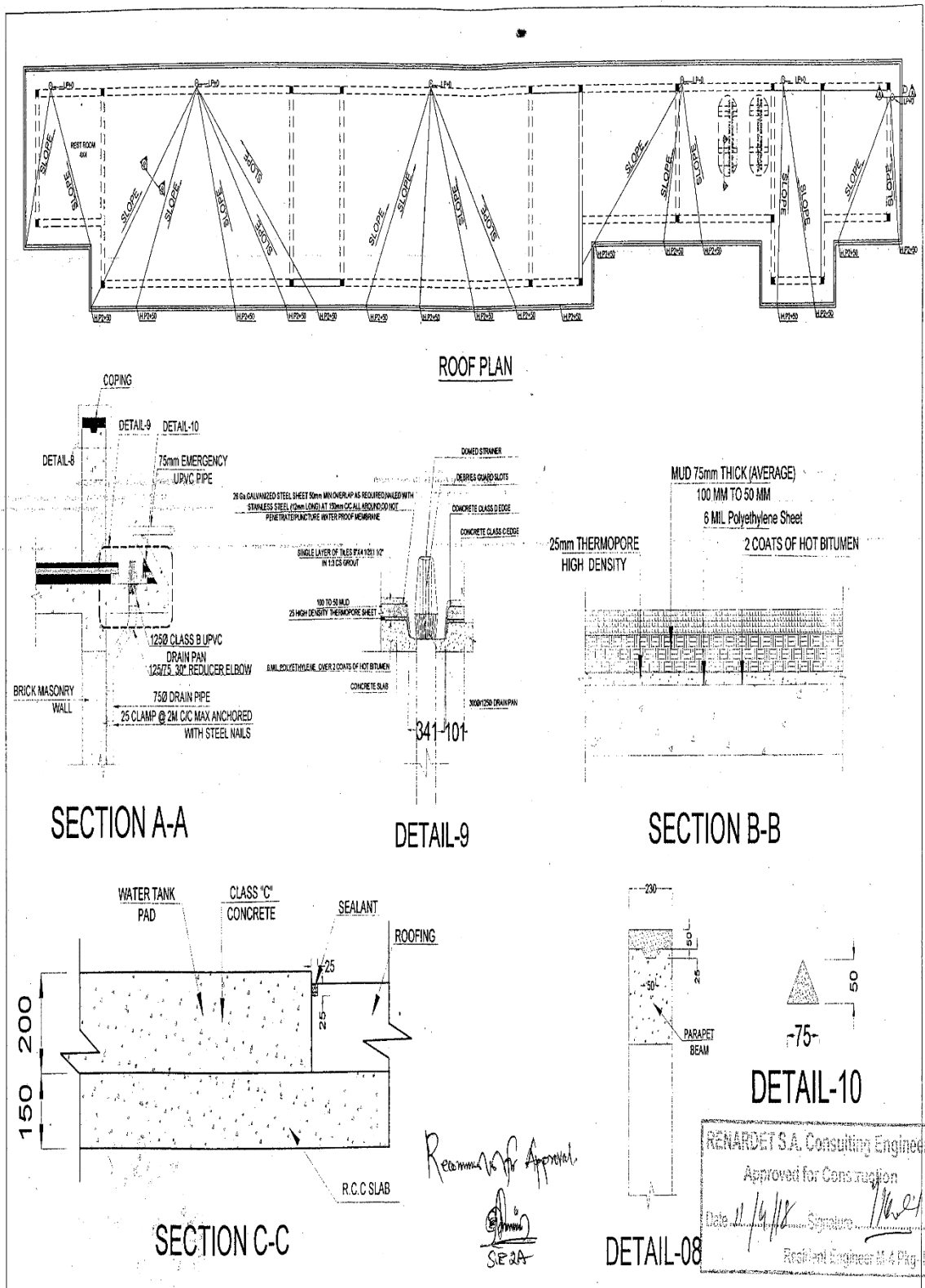

Recommended for Approval
[Signature]
 SEP 2018

RENARDET S.A. Consulting Engineers
 Approved for Construction
 Date 11/09/18 Signature *[Signature]*
 Resident Engineer M 4 Pkg. 04

Employer: National Highway Authority Ministry of communication Government of Pakistan	Consultant: Renardet S.A. ENGINEERS CONSULTANTS	Contractor: Xin Jiang Beixin Road & Bridge Group Co., Ltd BEIXIN	Project: Motorway (M-4) Package-II A Gojra-Jamari	Title: REST AREA ROOF PLAN & DETAILS	Submitted:
			Ref: BX/M/RSA/CE/2018/01	Date: 19/03/2018	Drawing No.: M4-PII-A-CD-RA-A-04

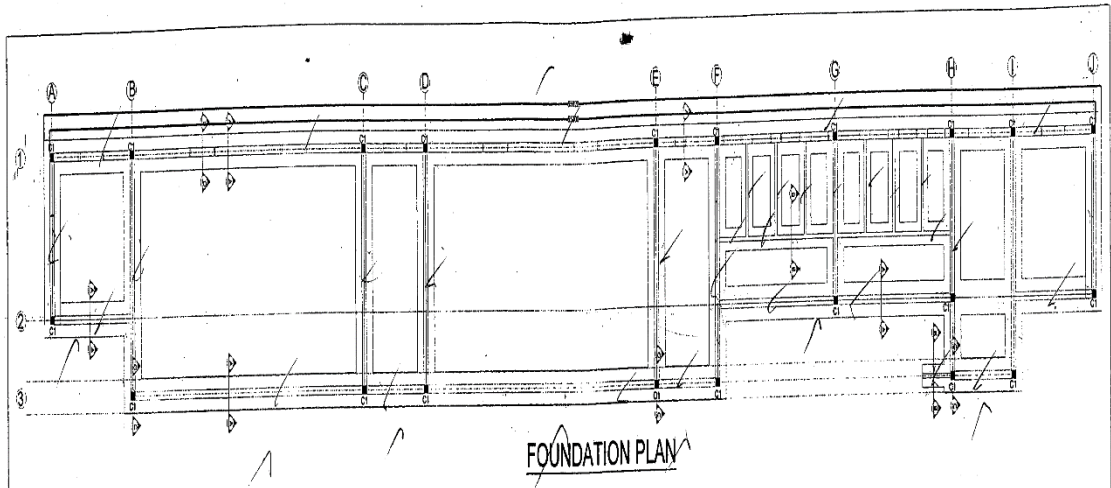

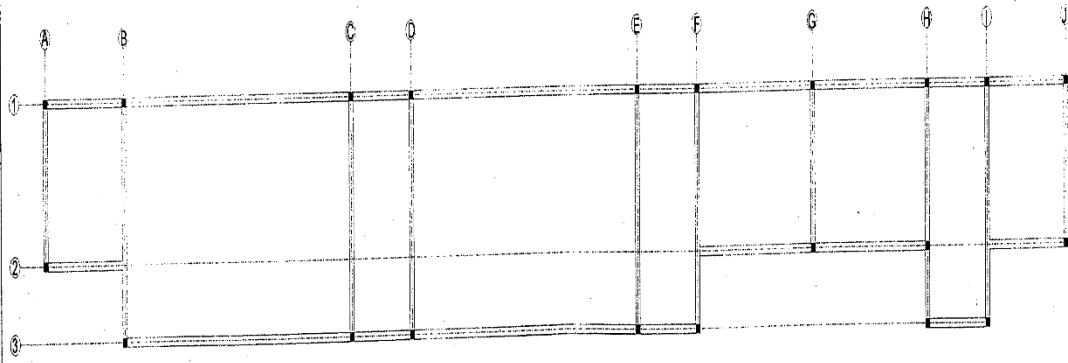

RENARDET S.A. Consulting Engineers
 Approved for Construction
 Date: 11/14/18 Signature: *[Signature]*
 Resident Engineer M-4 Pkg-IIA



PLINTH/SILL/LINTEL

Responsible for Approval
[Signature]
 SEBA

Employer:  National Highway Authority Ministry of communication Government of Pakistan	Consultant:  Renardet S.A. CONSULTING ENGINEERS	Contractor:  Xinjiang Beixin Road & Bridge Group Co., Ltd BEIXIN	Project: Motorway (M-4) Package-IIA Gojra-Jamami Ref: BK/MAR/SACE/2018/40	Title: REST AREA FOUNDATION PLAN & PLINTH/SILL/LINTEL Date: 19/03/2018 Drawing No.: M4-PII-A-CD-RA-S-01	Submitted: <i>[Signature]</i> Approved:
--	--	--	--	--	---

"OPERATION & MANAGEMENT OF GOJRA REST AREA AT KM-168+000 NORTH & SOUTH BOUND ON MULTAN - FAISALABAD - PINDI BHATTIAN MOTORWAY (M-4) ON ADVANCE NET GUARANTEED RENTAL BASIS"

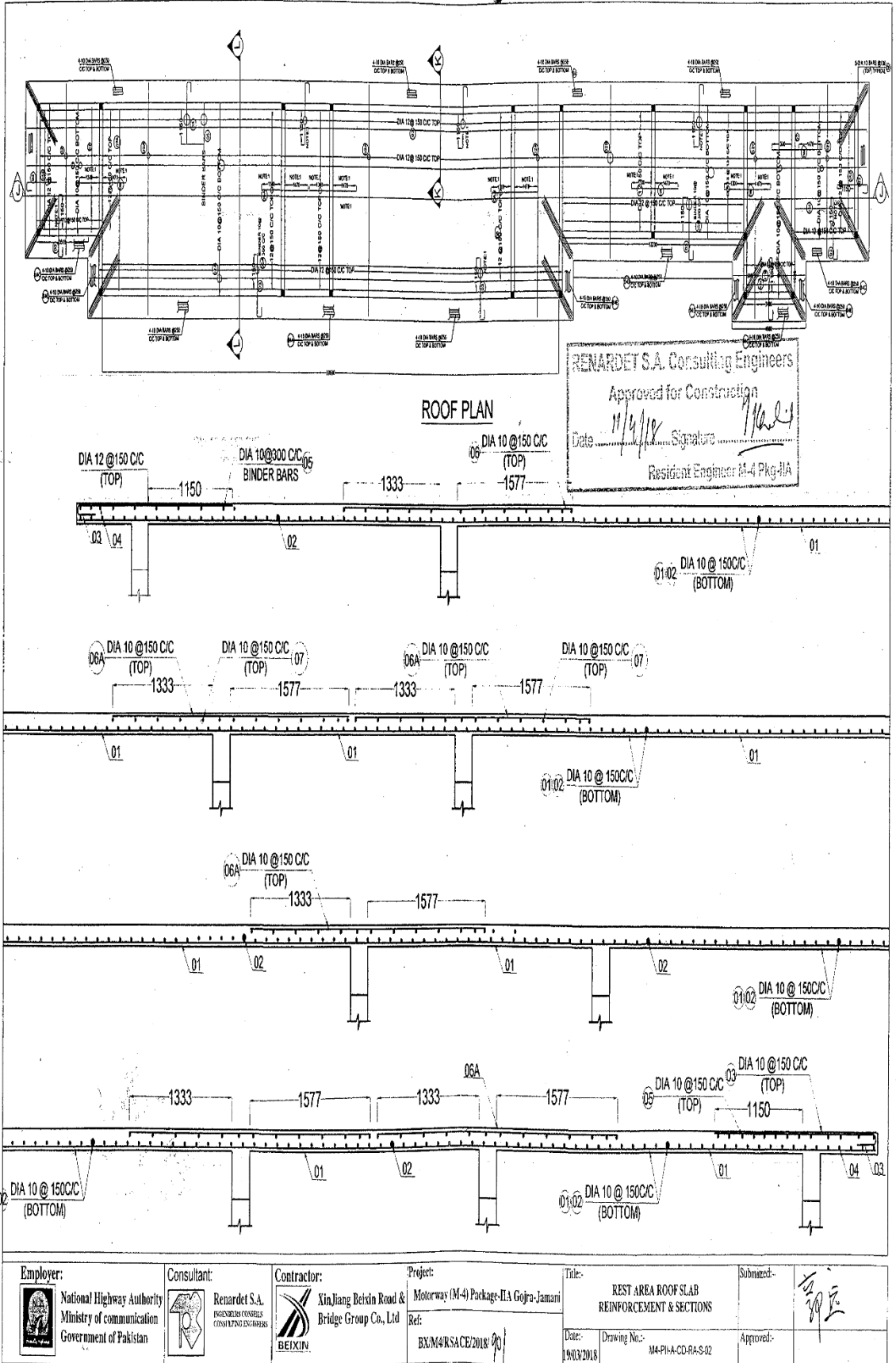

Recommended for Approval

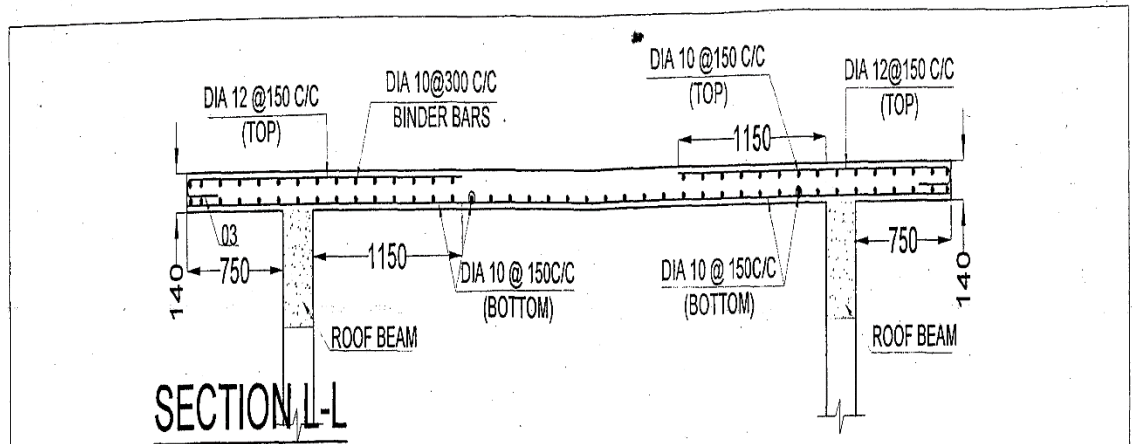

SECTION L-L

LAYER NO.	THICKNESS mm.	DESCRIPTION
1	125	FINISH FLOOR TOPPING
2	200	P.C.C (1:2:4)
3	6 MIL	POLYTHYLENE
4	150	STONE
5	150	GRANULAR MATERIAL (A-3)
6	AS REQUIRED	COMPACTED EARTH

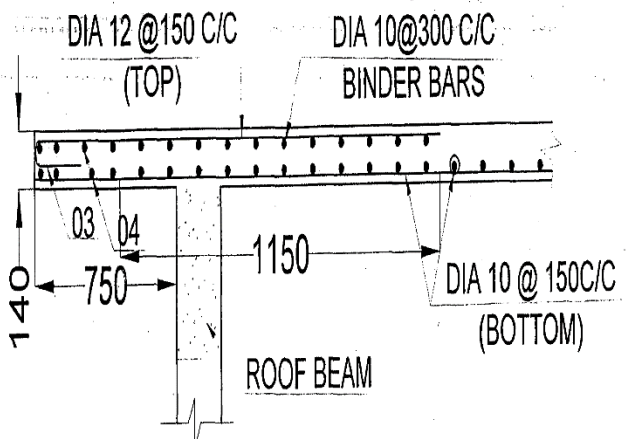

SECTION K-K

Recd. for Approval

 S.E. SA

RENARDET S.A. Consulting Engineers
 Approved for Construction
 Date: 11/9/18 Signature: *[Signature]*
 Resident Engineer M-4 Pkg-IIA

Employer: National Highway Authority Ministry of communication Government of Pakistan	Consultant: Renardet S.A. ENGINEERS CONSULTANTS CONSULTING ENGINEERS	Contractor: Xinjiang Beixin Road & Bridge Group Co., Ltd.	Project: Motorway (M-4) Package-IIA Gojra-Jamali Ref: EX/M4/RSACE/2018/00	Title: REST AREA ROOF SLAB REINFORCEMENT & SECTIONS	Submitted: <i>[Signature]</i>
				Date: 19/03/2018	Drawing No.: MA-P1-A-CD-PA-S-03

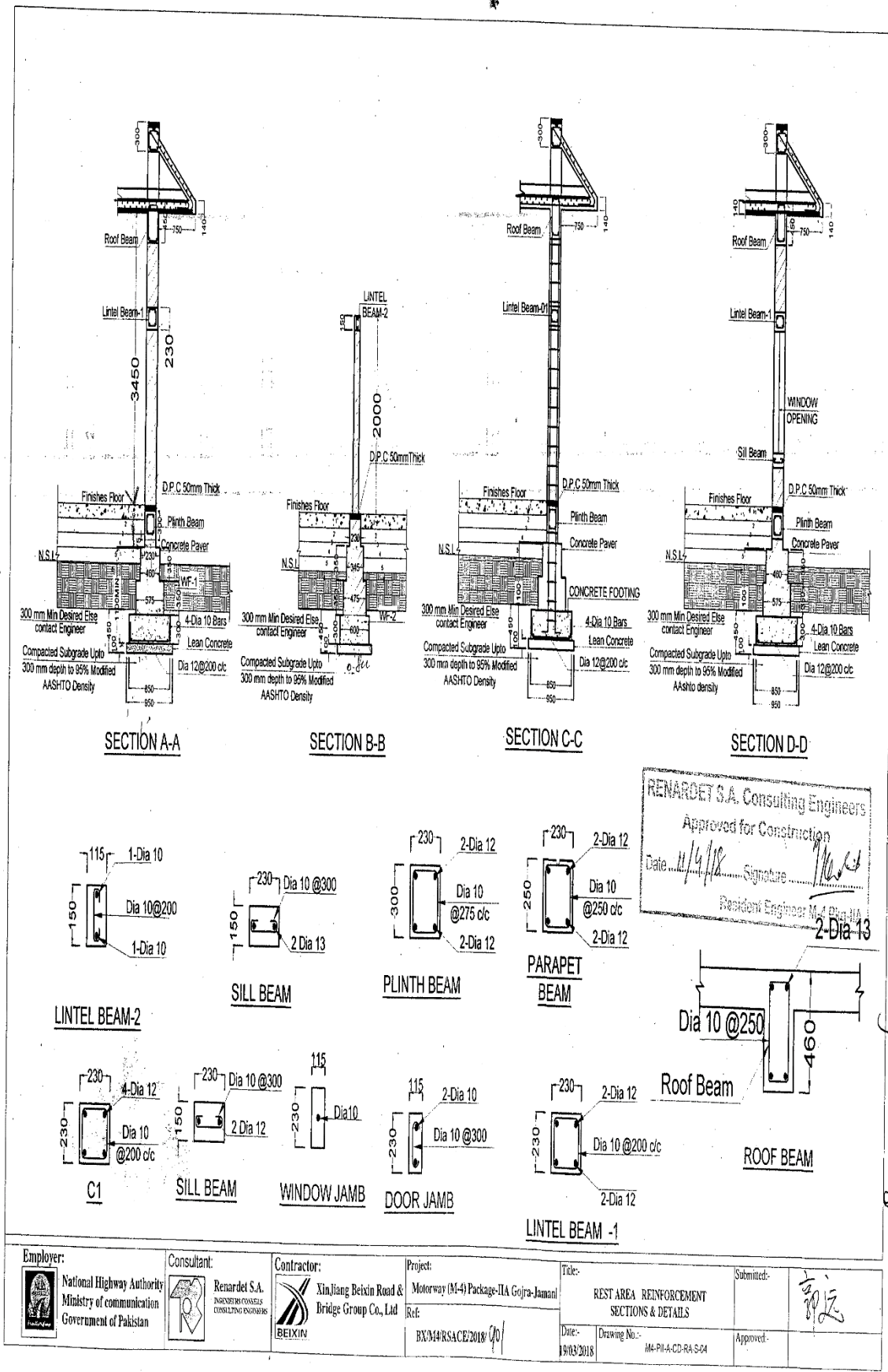

VI. FINANCIAL BID FORM

THE BID

FOR

“OPERATION & MANAGEMENT OF GOJRA REST AREA AT KM-168+000 NORTH & SOUTH BOUND ON MULTAN – FAISALABAD – PINDI BHATTIAN MOTORWAY (M-4)”

Amount of Net Guaranteed Rentals		
Description	In Figure	
	Per Month (A)	Per Annum (B=Ax12)
Advance net guaranteed Rental for the NHA Assets of Gojra Rest Area at KM-168+000 both North & South Bound on Multan - Faisalabad - Pindi Bhattian Motorway (M-4), from the date of commencement.		
Advance Net Guaranteed Rentals per Month in Words		

The guaranteed monthly rentals shall be increased accumulatively @ 10% each year subsequently.

Guaranteed rentals shall be deposited for three (03) months in advance by the Operator by 5th of respective month to **“National Highway Authority, Road Maintenance Account, Islamabad” in the form of Pay order to be deposited at Revenue Section NHA HQ under intimation to concerned GM.**

In addition to Net Guaranteed Rentals, payment of all applicable taxes on net guaranteed Rentals shall be the responsibility of bidder and the same is required to be deposited as per prevailing Tax laws of Pakistan.

After completion of the contract, the Operator shall handover all the established/constructed facilities/amenities to NHA without any claim to cost or any terms & conditions as the Employer i.e. NHA will re-tender (or otherwise as it deems fit) the subject facility on its expiry for further operations in accordance with the provisions of NHA code and PPRA Rules.

Signature of Bidder

With Name, CNIC No. and seal of the firm

Address: _____